

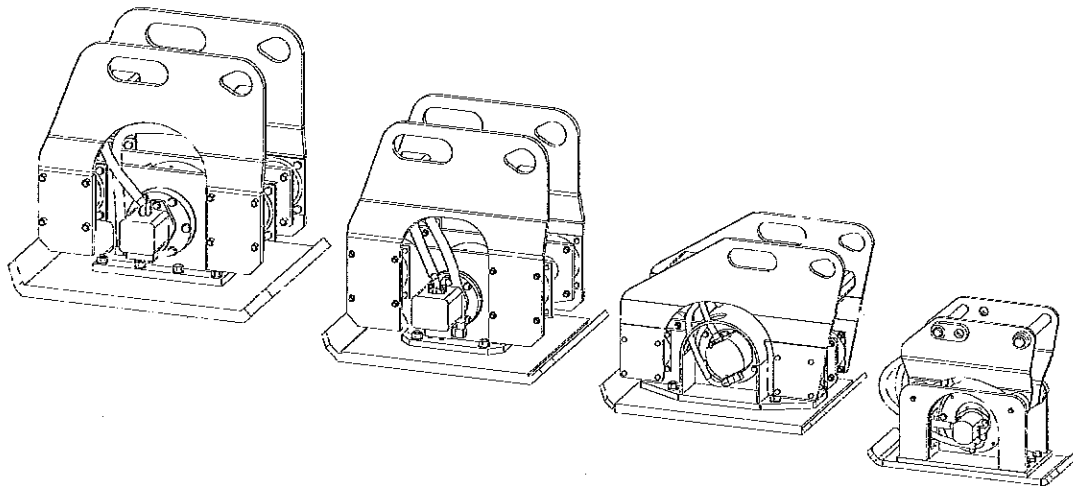

# COMPACTION HANDBOOK

---

Manual Part Number 103392  
July 2004



## MACHINE MOUNTED VIBRATORY PLATE COMPACTORS

---

**Allied Compaction Handbook  
Document Change Notice**

<u>Date</u>	<u>Page</u>	<u>Change</u>
Jul 22, 2004		Initial Issue

## TABLE OF CONTENTS

<b>Section</b>	<b>Page</b>
SECTION 1.0 INTRODUCTION/OVERVIEW	1
SECTION 2.0 SOIL	2
2.1 What is soil	2
2.2 How to recognize soil types	2
SECTION 3.0 COMPACTION	3
3.1 What is compaction	3
3.2 Why is compaction necessary/desirable	3
3.3 How is compaction achieved	3
3.4 How does type of soil or substrate affect compaction	4
3.5 How does moisture content affect compaction	5
3.6 How is compaction measured	6
3.6.1 Field density measurement relative to a standard	6
3.6.2 Description of field measurement methods	7
SECTION 4.0 TYPES OF AVAILABLE COMPACTION EQUIPMENT	8
4.1 Rammers, plates, rollers	8
4.2 Hand-guided, machine/boom-mounted, self-propelled	8
4.3 How is dynamic compaction force determined	8
4.4 Which compaction methods are best suited for which types of soil/substrates	9
SECTION 5.0 ALLIED COMPACTION EQUIPMENT	10
5.1 What type of machine-mounted compaction equipment is available from Allied	10
5.2 How does Allied compaction equipment work	11
5.3 What is the range of available Allied compaction equipment	11

## TABLE OF CONTENTS (cont'd)

<b>Section</b>	<b>Page</b>
SECTION 6.0 COMPACTION TECHNIQUE USING ALLIED EQUIPMENT	12
6.1 How do you attach Allied compaction equipment	12
6.2 How do you prepare the area for compacting	12
6.3 How do you operate a machine-mounted compactor	13
6.3.1 Disclaimer	13
6.3.2 Lift heights	13
6.3.3 Machine positioning, pattern, duration, down-force finish pass	13
6.3.4 Safety issues to observe and what to avoid during operation of a machine-mounted compactor	15
SECTION 7.0 ALLIED COMPACTOR PERFORMANCE DATA	16
7.1 Disclaimer	16
7.2 Data gathering procedure	16
7.3 Ho-Pac compactor performance data	17
SECTION 8.0 OTHER OPERATIONS WITH ALLIED COMPACTING EQUIPMENT	20
8.1 Pile driving	20
8.1.1 Theory	20
8.1.2 Technique	20
8.2 Other applications	21
SECTION 9.0 DEFINITION OF TERMS/GLOSSARY	22
SECTION 10.0 REFERENCES AND FURTHER READING	24

## **Section 1.0 Introduction/Overview**

This handbook contains background information about soil, soil compaction and basic soil compaction equipment. It also contains general information about the operation of Allied Construction Products' Ho-Pac® machine-mounted vibratory compactor/drivers, as well as performance data for Ho-Pac compactor models derived from field tests.

For safety precautions, technical information including specifications, service/maintenance information, storage recommendations, warranty information and product policies applying to individual Ho-Pac compactor models, refer to the specific Technical Manual provided by Allied Construction Products for that Ho-Pac model.

## Section 2.0 Soil

### 2.1 What is soil?

Soil is a combination of mineral and organic particles. Spaces between the particles may

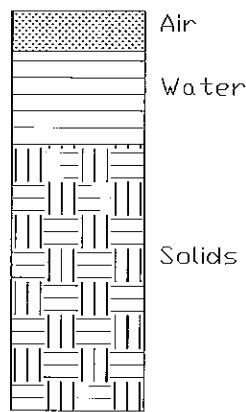

**Idealized Soil Diagram**  
**Fig 2.1**

be occupied by air or moisture. The particles vary in size and shape and composition. Soils are commonly classified by grain sizes, measured by passing the soil through a series of screens/sieves with different mesh sizes. Soils fall into three general categories: organic, granular, and clay/cohesive.

Organic soils contain large concentrations of vegetable and animal material (humus, peat) in various stages of decomposition and are not suitable for compaction and the support of rigid construction. Therefore, no further mention of organic soils will be made.

Granular soil particles are typically sands and gravels, with 20% or more granular content. The particles range in sieve size from 0.003" (sand) to 1.0" (medium gravel).

Relatively large spaces between the "lumpy" grains allow water to readily drain through the soil.

Clay or cohesive soil particles are typically very small, flat "platelets," ranging in sieve size from .00004 to .002", with less than 20% granular content. The platelets pack tightly together, held by molecular attraction, and clay soils are very dense. Drainage through clay is poor.

### 2.2 How to recognize soil types.

Granular soils may be distinguished from clay or cohesive soils by visual examination, feel and response to water

Granular soils have visible grains of sand and gravel. They feel gritty when rubbed between the fingers. They readily mix with water. The particles settle (or the water drains out) when mixing stops. When wet, there is little or no plasticity (soil will not retain shape when molded). When dry, there is little or no cohesive strength (soil crumbles easily).

Clay soils have no particles visible with the naked eye, and feel smooth and slippery when rubbed between the fingers. They will not readily mix with water, and, when wet, the surface is slick and greasy. Also, when wet, clay soils can readily be molded and, if rolled into a slender 'rod' shape, they will retain that shape when the rod is held by one end. When they are dry, clay soils have high strength, crumble with difficulty and are slow to saturate with water.

## Section 3.0 Compaction

### 3.1 What is compaction?

Compaction is the process of mechanically increasing the density or unit weight (lb/ft<sup>3</sup>) of soil by packing the soil particles closer together to force out air.

### 3.2 Why is compaction necessary or desirable?

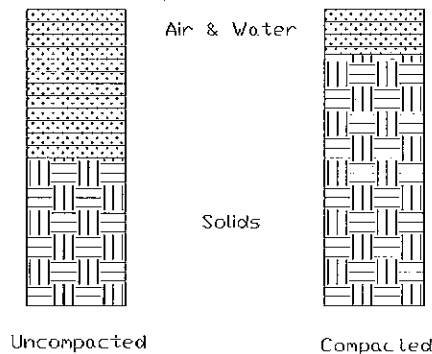

**Idealized Uncompacted/Compacted  
Soil Comparison**

**Figure 3.1**

When soil is disturbed by excavation, soil particles become separated by air pockets. The volume of the soil increases greatly, thereby greatly reducing its density. While all disturbed soils will settle (become more dense) with time, mechanical compaction greatly reduces the time for this to occur.

Soil must be as dense as possible to maximize its load carrying capability, provide stability and minimize subsequent settling that can result in cracking or displacement of supported structures, paved surfaces, pipelines, etc. Compaction also

reduces subsequent water seepage, swelling and contraction.

### 3.3 How is compaction achieved?

Compaction is achieved through the application of mechanical force to layers or “lifts” of the disturbed soil. This force overcomes friction between the soil particles and causes the particles to move closer together. Compaction falls into two major categories, static and dynamic.

Static compaction is simply the application of extreme force to the disturbed material, causing it to compress until it is capable of supporting the applied force. Dynamic compaction achieves the desired result by introducing waves of motion in the soil that set the soil particles in motion, causing them to reorient and fill vacant spaces, thus making the soil denser.

Static forces include kneading and compression and are typically applied by non-vibratory (sheepsfoot and smooth) rollers. Static compaction is typically limited to the soil/material near the surface and is most effective for thin layers of non-granular materials and asphalt.

Dynamic forces include impact and vibration and are applied by a variety of hand-guided and machine-mounted devices that generate stress waves that are transferred to the soil.

Impact compaction equipment (also known as rammers/tampers) generates a lower-frequency, longer-stroke (compared to vibratory) motion. This motion is used to break soil “clumps” into smaller pieces and

push the pieces closer together. Impact compaction is more effective for soils with less than 50% granular content, such as clay soils.

Vibration compaction equipment generates a higher frequency, smaller stroke motion. This motion, or stress wave, is transferred to the soil by direct contact. The stress wave causes the soil particles to move and vibrate, effectively “liquefying” the soil, which allows the soil particles to fill voids between them. The result is a denser, more compact soil. Vibration compaction is most effective for soils with 50% or more granular content.

### **3.4 How does type of soil or substrate affect compaction?**

Soil properties that affect the ability of soil to be compacted and also suggest the best compaction force for the job include shear resistance, elasticity, cohesion, permeability and volume change (swelling /shrinkage).

Shear resistance is the resistance of soil particles to movement under applied compaction force resulting from friction between the particles. The greater the friction force and the greater the contact area between particles, the more difficult it is to compact the soil. This explains why clay soils are more difficult to compact than granular soils.

Elasticity is the property of a soil mass that causes it to return to its original form after deformation (a load is applied and removed). ‘Spongy’ organic soils have a high degree of elasticity that makes them unsatisfactory as a base for surfaces such as roads that experience cyclical loads which can lead to flexing and cracking of the paved surface if poorly supported.

Cohesion is the property of soil particles that causes them to stick to one another. It is stronger in clay soils than in granular soils.

Permeability is a characteristic of soil that allows water to flow through it as a result of gravity and has a major effect on its compactability. See Section 3.5 for further discussion of the effect of moisture content on compaction.

Volume Change as a result of changes in moisture content is a critical consideration when soils are used as subgrades for roads. Volume change is generally not a great concern in relation to compaction except for clay soils where compaction does have a marked influence. With these soils, the greater the density, the greater the potential volume change as a result of swelling. Swelling also has a negative effect on load bearing capacity.

Another characteristic of soil that affects its compact-ability is the presence or absence of “binder” materials, small particles or “fines” that fill voids between larger particles and hold gravel together when dry. A soil that consists of a wide range of particle sizes, with the smaller particles filling the voids, forms a dense mass that compacts well.

Refer to Table 3.1 for some typical soil behavioral characteristics.

**Table 3.1 Typical Soil Behavioral Characteristics**

	Permeability	Foundation Support	Pavement Subgrade	Expansive	Compaction Difficulty
<b>Gravel</b>	Very High	Excellent	Excellent	No	Very Easy
<b>Sand</b>	Medium	Good	Good	No	Easy
<b>Silt</b>	Medium Low	Poor	Poor	Some	Some
<b>Clay</b>	Very Low	Moderate	Poor	Common	Very Difficult
<b>Organic</b>	Low	Very Poor	Very Poor	Some	Very Difficult

**3.5 How does moisture content affect compaction?**

Moisture content is the amount of water in a soil, expressed as a percent of the total weight of the soil. Achieving and maintaining the optimum moisture content is very important for proper compaction. Optimum moisture content is defined as the percentage of moisture that results in the highest density (fewest air voids) of the compacted material after the water is removed.

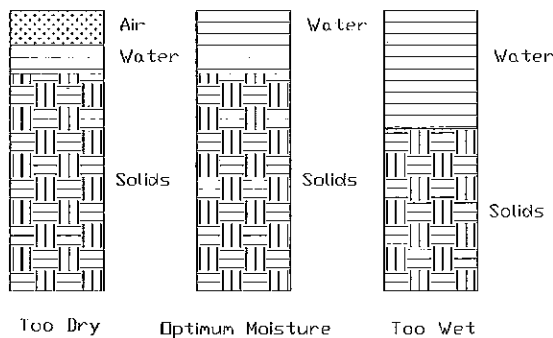

**Idealized Soil Moisture Comparison  
Figure 3.2**

Without water, the soil particles will not stick together. Water also acts as a

lubricant, allowing the particles to slide together and fill air voids during compaction.

While every soil responds differently, soils with a moisture content near the optimum are more effectively compacted and result in greater compaction densities.

However, if too much water is added, soil density decreases (soil becomes spongy) because the water displaces soil particles, expanding the volume of the soil and transforming it into a plastic state with little or no load bearing ability. (See Section 3.6.1 for a discussion of soil density measurement.)

Moisture content has less effect on the compact-ability of heavy clays than on slightly plastic, clayey sands and silty sands. However, if heavy clay is compacted wetter than 2% above the optimum moisture content, it becomes too fluid and difficult to work. Poorly graded soils (with an uneven concentration of particle sizes) are also relatively unaffected by changes in moisture. On the other hand, granular soils with better grading and higher densities react sharply to slight changes in moisture, resulting in sizable changes in dry density.

**3.6 How is compaction measured?**

**3.6.1 Field density measurement relative to a standard.**

Field compaction (density) measurements are based on comparisons with the results of standardized laboratory tests. The Proctor test, a standardized laboratory test widely used in the USA, was developed in the 1930's. The original Proctor test was eventually modified to make it more suitable for evaluating soils capable of supporting heavier loads. These tests led to AASHTO (American Association of State Highway and Transportation Officials), ASTM (American Society for Testing and Materials) and other tests that are widely used to determine the optimum soil density and moisture content for a soil sample.

In the standardized laboratory tests, soil taken from the jobsite is divided into portions. Each portion is mixed with a different amount of water to produce a range of samples, each having different moisture contents.

Each sample is then placed in a graduated cylindrical container (with a known volume). A specified weight or hammer is dropped on successive layers of the soil from a specified height, for a predetermined number of blows. The compacted volume is recorded and the compacted material is weighed to establish a "wet" density.

The material is then oven dried and reweighed to determine what the water content was at the time of compaction and a "dry" density is determined. The dry density for each sample is plotted against the moisture content at which it was attained. A curve is then drawn through the points to determine the moisture content at which the greatest compacted density will be obtained.

This density is referred to as "100% of Proctor." (See Figure 3.3)

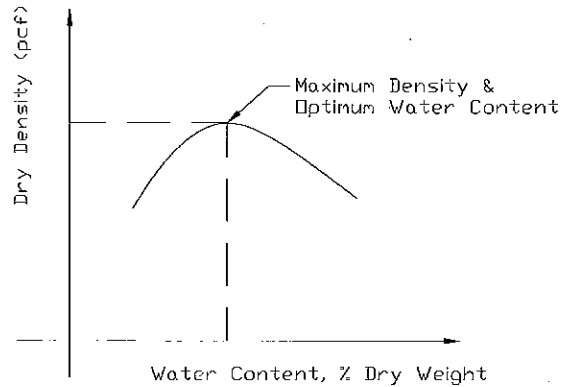

**Maximum Density & Optimum Moisture Diagram  
Figure 3.3**

Once this laboratory value is established, the field compaction objectives can be specified as percentage of Proctor. For example, a compaction specification of "95% of modified Proctor" means that the field compacted soil density should be 95% of the value established by the modified Proctor laboratory test.

The density of a compacted sample taken from the field site is measured and compared to the laboratory reading to see if the specification has been met. (See Section 3.6.2 for descriptions of various field measurement methods.)

Percent of Proctor =

$$\frac{\text{Field Density Measurement}}{\text{Max Laboratory Density Measurement}}$$

**3.6.2 Description of field measurement methods**

There are several traditional soil density field tests, including the Sand Cone Test, the Balloon Test and the Shelby Tube test. However, most soil density field tests done today are performed with a nuclear density gauge. This device quickly and accurately determines soil density and moisture content.

In the traditional field tests, a sample of the compacted material is removed and the volume of the cavity created by the sample is measured.

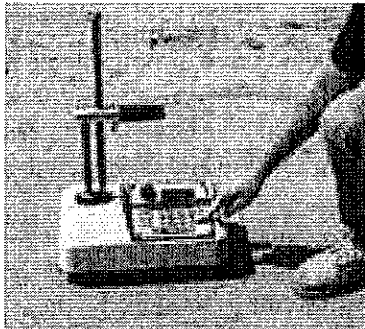

**Troxler 3430 Nuclear Density Gauge  
Figure 3.4**

The sample material is weighed and its wet compacted density is calculated. It is then dried and again weighed to determine the dry density. The original moisture content and dry density are then located on the Proctor curve to determine if the material has been compacted to the % Proctor specified.

In the nuclear density gauge test, the Proctor density and optimum moisture content are programmed into the nuclear density gauge. A detector probe is inserted into the soil to the desired depth. Gamma rays are emitted from the probe. Some gamma rays are absorbed by the soil and water in the compacted material. The denser the soil and the greater the water content, the more rays are absorbed.

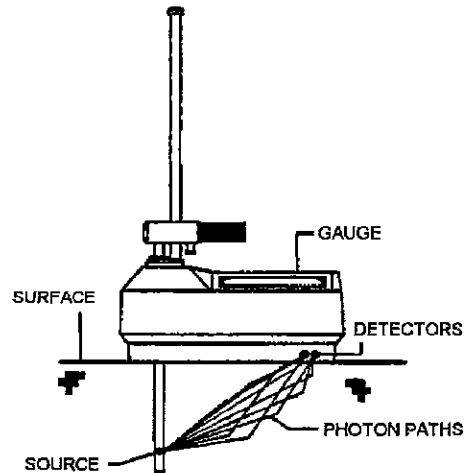

**Nuclear Density Gauge Operational  
Diagram  
Figure 3.5**

Those rays not absorbed by the compacted material are sensed by a detector/counter in the nuclear density gauge. The denser the soil, the lower the count. The nuclear gauge provides readouts of radiation counts, wet and dry densities, moisture content and (by comparison with the programmed Proctor values) percent of Proctor.

## Section 4.0

### Types of Available Compaction Equipment

#### 4.1 Rammers, plates, rollers

Compaction equipment falls into four general categories: rammer/tampers, vibratory plates, vibratory rollers and static rollers. Rammers produce impact forces, plates produce vibratory forces, vibratory rollers produce vibratory forces and static forces, and static rollers produce static and kneading forces.

#### 4.2 Hand-Guided, machine/boom mounted, self-propelled

Rammer/tampers are hand-guided and use a large piston set and springs to create a high impact force at relatively few blows (500-750) per minute (compared to vibratory compactors).

Vibratory plates may be hand-guided or machine-mounted on vehicles with hydraulic booms. Reversible vibratory plates combining two counter-rotating eccentric weights are also available. Motor-driven eccentric weights develop a lower impact force per blow than comparably sized rammer/tampers, but deliver many more blows (2000-6000) per minute.

Rollers may be hand-guided walk-behind models, towed behind rubber-tired or track-mounted tractors, or self-propelled. Static rollers rely on weight for compaction, while vibratory rollers develop compaction forces through a rotating eccentric weight arrangement mounted inside the roller drum.

#### 4.3 How is dynamic compaction force determined?

The compacting force generated by dynamic compactors (rammer/tampers, vibratory plates/rollers) is a function of the amplitude of the motion and the frequency at which the moving surface changes directions.

With rammer/tampers, the amplitude is one-half the height the machine jumps. With vibrating devices, the amplitude is the maximum movement of the vibrating body in one direction from its at-rest or neutral position. The apparent amplitude or the height the machine lifts itself off the ground between blows increases as the material becomes more dense and compacted.

With rammer/tampers, the frequency is the number of times the machine jumps per minute. With vibrating devices, the frequency is the rotational speed of the eccentric shaft.

When combined with the mass of the device, these two factors result in an "impulse force" or "centrifugal force," indicating the compaction force of the device. Impulse force is specified in pounds or newtons.

The working or operating weight of hand-guided and self-propelled equipment and the down-force applied to boom-mounted vibratory compactors provide a preload force to properly transmit the energy into the soil.

#### **4.4 Which compaction methods are best suited for which types of soil/substrates?**

Certain methods of compaction are best suited to specific soil conditions and situations. The compactor operator must be aware of the type of soil being compacted and be prepared to adjust the compaction technique to achieve the desired results.

In cases where the soil is a mixture of types (granular, clay), select the best method for the type of material that represents the largest percentage of the material to be compacted. In some situations, testing may be needed to determine the best technique.

##### **Granular soils—**

Where particles move freely against one another, such as sand and gravel, vibration will cause the particles to move and settle. Vibratory compacting is well suited for granular soils. The particles respond to different vibration frequencies. As the size of the particles increases, heavier equipment with lower frequencies and higher compaction forces (amplitudes) should be used.

##### **Clay and other cohesive soils—**

Where the soil particles stick together, a high impact force is required to rearrange the particles and force the air out.

Compactors that generate squeezing and kneading forces such as rammer/tampers and rollers are well suited for cohesive soils. When using vibratory compactors, reduce lift heights to achieve the best results.

##### **Sand and clay mixture—**

Compaction equipment is less effective in semi-cohesive soils that require increased compaction force, compared to granular soils. As with clays and other cohesive soils, when using vibratory equipment, reduce lift heights and increase the amount of compaction time to achieve desired results.

##### **Confined vs. unconfined areas—**

In confined areas, all types of compactors are generally effective with granular soils. In unconfined areas, compactors tend to push the soil aside rather than compacting it. However, vibratory compactors that settle the soil tend to be more effective than rammer/tampers. Confinement or lack of it has less effect on the compact-ability of clay soils.

**Section 5.0  
Allied Compaction Equipment**

**5.1 What type of machine-mounted compaction equipment is available from Allied?**

Allied Construction Products' Ho-Pac® compactors are hydraulic-powered vibratory-plate compactor/drivers (see Figure 5.1). They are designed for carrier mounting on mobile equipment with hydraulic booms, such as track-mounted backhoes and excavators, mini-excavators, rubber-tired backhoes and trenchers with backhoe attachments. (They may also be used for driving posts and pilings. See Section 8.0.)

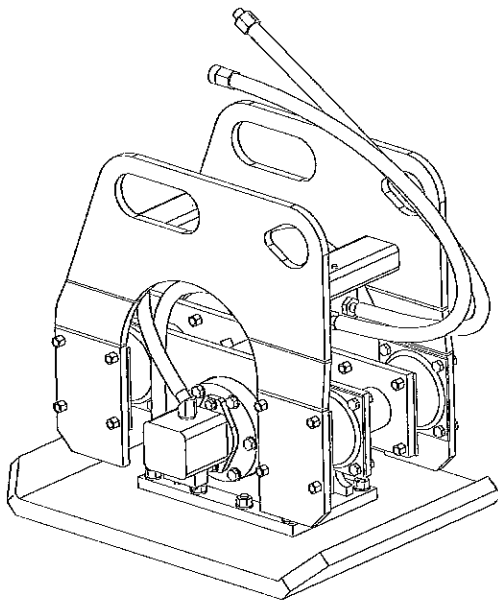

**Typical Allied Ho-Pac  
Figure 5.1**

The Ho-Pac vibratory-plate compactor consists of four major subassemblies:

The Dynamic Assembly includes a hydraulic motor, bearings, eccentric mass, housing frame and base plate.

The Suspension System is composed of four rubber spring mounts that suspend and isolate the Dynamic Assembly from the Mounting Frame.

The Mounting Frame is a steel-plate fabrication that supports the Dynamic Assembly and provides attachment points for connecting the compactor to the boom of the carrier.

The Hydraulic Control Valve is a multi-function, hydraulic control valve that regulates hydraulic flow and protects the Ho-Pac from excessive hydraulic pressures and flows.

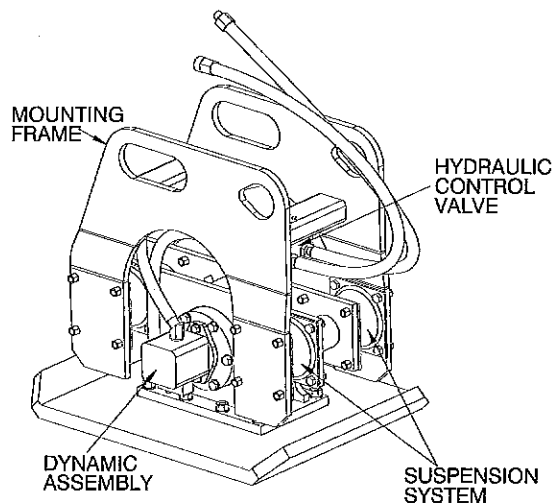

**Allied Ho-Pac Major Subassemblies  
Figure 5.2**

**5.2 How does Allied compaction equipment work?**

The eccentric mass is supported on bearings within the dynamic assembly and is rotated by the hydraulic motor (powered by the carrier hydraulic system). The rotating eccentric mass creates impulse forces that are transferred through the base plate into the soil being compacted. The soil near the base plate begins to vibrate, rearranging the soil particles that come closer together, thus eliminating voids between the particles and forcing out air that was trapped in the voids. The down-force applied through the boom of the carrier provides a pre-load force to effectively transfer the vibrating energy into the soil and to follow the material as it compacts. The actual compaction effect of the down-force is minimal.

**5.3 What is the range of available Allied compaction equipment?**

Allied's Ho-Pac hydraulic vibratory compactors are available in different configurations and sizes to accomplish a variety of compaction operations and facilitate attachment to various carriers, including mini-excavators, backhoes, and rubber-tired and track excavators. Complete specifications are available in Allied technical manuals and other documents accompanying each model.

Improvements to Allied compaction equipment are continuously under development. Contact your Allied Distributor for information about the latest Allied compaction equipment offerings.

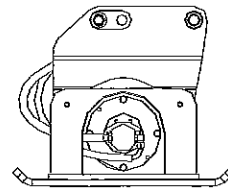

HoPac 500  
Carriers 4,000 to 15,000 Lbs.

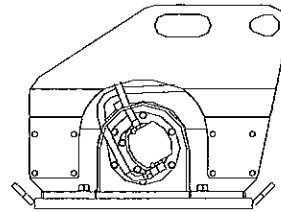

HoPac 1000  
Carriers 9,000 to 30,000 Lbs.

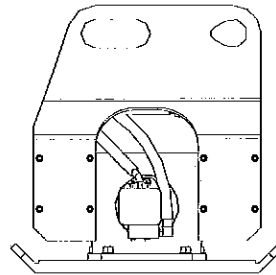

HoPac 1600  
Carriers 19,000 to 45,000 Lbs.

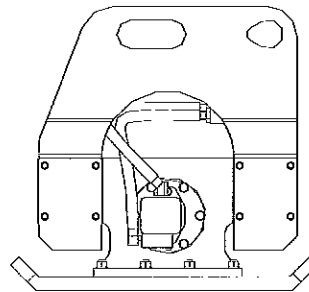

HoPac 2300  
Carriers 35,000 to 120,000 Lbs.

**Allied Ho-Pac Compaction Equipment  
Figure 5.3**

**Section 6.0**  
**Compaction Technique Using Allied Equipment**

**6.1 How do you attach Allied compaction equipment?**

Ho-Pac vibratory compactors can be attached to a wide range of backhoe, mini-excavator and excavator models. A variety of Ho-Pac mounting frame configurations and hardware kits are available to connect the compactors to carrier arms. A swivel mounting configuration is also offered that allows compactors to operate at either a 45° or a 90° angle to the boom, and custom mounting kits can be built to accommodate many quick-coupler systems.

The carrier hydraulic system is used for hydraulic oil flow and pressure and must be adequate to provide maximum compactor performance while maintaining carrier function. Allied hydraulic installation kits are designed to match Ho-Pac compactors to specific carriers. Depending upon the installation, kits may include a priority valve or a control valve to operate the carrier auxiliary valve.

Refer to the Ho-Pac Mounting and Hydraulic Kit Guide for available mechanical and hydraulic adapter kits. Refer to individual Ho-Pac Technical Manuals for complete mounting information and safety precautions.

**6.2 How do you prepare the area for compacting?**

Proper pre-conditioning of the soil is extremely important to achieve optimum results.

If compaction is being done to specification, first conduct a Proctor or other standardized

test to determine maximum density and optimum moisture content (See Section 3.6). Just prior to compaction, determine the moisture content of the backfill material.

If the moisture content is too high relative to the optimum as determined by the Proctor test, spread the material out and allow it to dry, or blend it uniformly with other dry material. If it is too low relative to the optimum, add water. Typically, plus or minus 2% is acceptable, but this range depends on the governing compaction specification.

The amount of water to be added to dry soil can be estimated:

$$V_{\text{water}} = 0.0012 \times D_{\text{target}} \times V_{\text{soil}} \times (W_{\text{target}} - W_{\text{actual}})$$

where;

$V_{\text{water}}$  = Volume of water in gallons,

$D_{\text{target}}$  = Target soil density in pounds per cubic foot,

$V_{\text{soil}}$  = Volume of soil to condition in cubic feet,

$W_{\text{target}}$  = Target moisture content in percent,

$W_{\text{actual}}$  = Actual moisture content in percent.

When the soil is properly conditioned, backfill the excavated area evenly with suitable equipment and in the appropriate lift heights, depending on the type of material, the depth of the excavation, and the compaction equipment being used.

### **6.3 How do you operate a machine mounted compactor?**

#### **6.3.1 Disclaimer**

COMPACTION RESULTS WILL VARY, DEPENDING UPON THE TYPE AND CONDITION OF MATERIAL BEING COMPACTED, THE CONFIGURATION OF THE AREA TO BE COMPACTED, THE TYPE OF COMPACTION EQUIPMENT BEING USED, AND THE OPERATOR'S TECHNIQUE.

The suggested operation technique for Allied vibratory plate compactors that follows should be considered as a starting point and general guideline.

#### **6.3.2 Lift heights**

The lift height or depth of the soil layer being compacted affects the degree of compaction that can be achieved and the amount of time required to reach the specified compaction level (specified % Proctor). If the lift is too thick, it will either take too long to reach the desired level of compaction, or the desired level will be unattainable.

Soil may also be over compacted, thereby wasting time, causing "cracking" of the compacted layer and creating unnecessary wear on the compaction equipment as excessive impact force is transferred back into the compactor. Overworking the soil also pulls moisture to the surface. This may cause the moisture content to shift from the optimum range and affect compaction results.

It may be necessary to try different lift heights to determine the most effective lift to achieve the desired level of compaction and maximize the productivity level of the operation.

#### **6.3.3 Machine positioning, pattern, duration, down-force, finish pass**

General—

Position the compaction plate on an area to be compacted. Apply enough down-force with the carrier boom to stretch the rubber spring mounts on the Ho-Pac approximately one half their width. This is necessary to adequately transfer the compaction energy to the soil. Activate the Ho-Pac. As soil density increases, the energy is transmitted deeper into the material.

During compaction, lower the boom to "follow" the material and maintain the one-half-width rubber spring deflection. Keep the Ho-Pac compaction plate in full view of the operator. Hold the compaction plate parallel to the work surface and maintain full contact with the material being compacted.

Continue to apply the compaction plate to the same area until refusal (until further compaction is no longer apparent). Depending on the type of material, the size of the compactor and the height of the lift, it may take approximately 10 to 15 seconds. This gives the material adequate time to respond to the energy being applied.

When the entire area has been compacted once, make a second pass, again applying the compaction plate to one area at a time until further compaction is no longer apparent.

Finally, make a light finish pass to smooth out high spots and establish the final grade. While the compactor is vibrating, make a “troweling” motion with the compaction plate, keeping it in contact with the compacted surface while swinging the carrier boom.

**Confined areas—**

Position the compaction plate over the area to be compacted, keeping the entire plate over the non-compacted area. If part of the compaction plate rests on undisturbed material next to the area to be compacted, the undisturbed material will prevent the compaction plate from thoroughly compacting the material in the excavation.

**Trenches—**

When compacting trenches, straddle the trench with the carrier and position it in line with the direction of work. Keep the compaction plate entirely over the fill material as described in the above discussion on confined areas.

An efficient technique for compacting pipe trenches is to slope the backfill. With this technique, the compaction operation can follow closely behind the pipe placement operation. With the carrier on the compact material, begin by compacting fill material into a corner, against a manhole, or against already compact material. Then place fill material to create a slope in the trench from the pipe, or trench bottom, to grade level at approximately a 45 degree angle. Compact the fill material starting at the bottom and working up the slope. The resulting compacted backfill provides a stable slope against collapse. Repeat this process with another layer of fill moving forward along the trench.

**Open areas—**

When compacting open areas too large to cover without moving the carrier onto the compacting area, start at the edge of the excavation and compact the back-filled material within reach of the boom before moving the carrier onto the compacting area. Continue to compact ahead of the advance of the carrier, compacting completely around the edge of the area. Then work toward the center of the area, continuing to compact along the edge of the remaining non-compacted material until the entire area has been compacted.

**Embankments—**

Begin at the bottom of the embankment, holding the compaction plate in line with the desired slope of the embankment. When a complete pass has been made along the base of the embankment, begin working up the slope. Continue making passes along the edge of the already compacted material until the top of the embankment is reached. Smaller lifts may be necessary to avoid non-compacted fill material from sliding down the embankment.

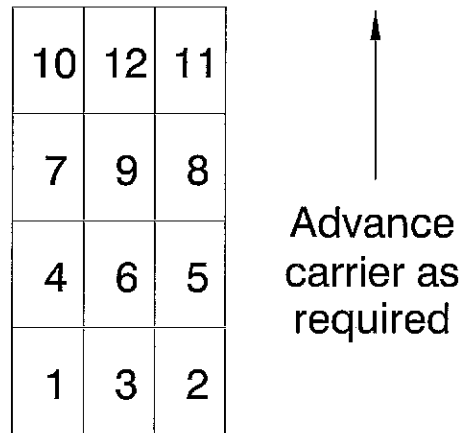

**Open Area Compaction Sequence  
Figure 6.1**

#### **6.3.4 Safety issues to observe and what to avoid during operation of a machine-mounted compactor?**

General construction safety precautions must be observed, such as locating existing underground service and utility lines, establishing pedestrian barriers and utilizing proper personal safety equipment including safety glasses and ear protection for all personnel in the immediate area.

**THE OPERATOR MUST READ THE OPERATOR'S HO-PAC TECHNICAL MANUAL PROVIDED WITH THE EQUIPMENT AND FOLLOW ALL OPERATING INSTRUCTIONS WHILE OPERATING THE COMPACTOR.**

Damage to the Ho-Pac compactor and the carrier may result if the compactor compaction plate is not evenly positioned on the material to be compacted. Unequal deflection of the rubber mounting springs may allow the metal components of the dynamic assembly to impact the mounting frame, possibly damaging the components of the compactor and transferring harmful vibrations into the carrier boom. Eventual damage to the rubber springs will also occur.

Investigate any unusual noises, excessive vibrations or erratic operation and remedy the cause(s) prior to continuing. **REFER TO THE HO-PAC TECHNICAL MANUAL FOR POSSIBLE CAUSES.**

## Section 7.0 Allied Compactor Performance Data

### 7.1 Disclaimer

These performance data are for reference purposes only. Results may vary depending on soil conditions, variations in operator technique, etc. It is recommended that the user perform tests with the actual material to be compacted prior to beginning the job to determine specific output rates and degrees of compaction.

### 7.2 Data gathering procedure

Data presented here for Ho-Pac vibratory compactors were gathered at the Allied Construction Products test facility in Marblehead, Ohio.

1. A pit was excavated and the excavated material was discarded.
2. Provision was made to remove any water that might accumulate in the pit from rain or other sources.
3. A supply of ODOT #411 (Ohio Department of Transportation) graded limestone aggregate was obtained and subjected to a standardized Proctor test (ASTM D698-00a METHOD C) by a certified construction materials testing firm to establish maximum density and optimum moisture content.
4. Prior to compaction, the moisture content of the #411 aggregate was measured and adjusted to bring it to within 2% of the optimum moisture content.
5. Measurement of the average depth of the empty pit was taken.
6. The pit was then filled with the prepared aggregate in various lift heights, depending on the compactor tested.
7. A measurement of the surface level of the non-compacted material was taken to determine the average height of the lift.
8. The material was then compacted with the Ho-Pac model being tested, using the general compaction procedure described in Section 6.3.
9. The surface level of the compacted lift was measured to determine the average compacted height of the lift.
10. Measurements were taken and recorded at four points at a prescribed depth below the surface with a nuclear density gauge by a certified construction materials testing firm to establish the density, moisture content and % of Proctor of the compacted material.
11. A layer of compacted material approximately equal to the length of the nuclear density gauge probe was carefully removed.
12. Steps 10 and 11 were repeated until the desired depth was reached or density readings fell below 95% of Proctor.

Data were summarized and plotted for each Ho-Pac model and are presented in the Section 7.3.

**7.3 Ho-Pac compactor performance data**

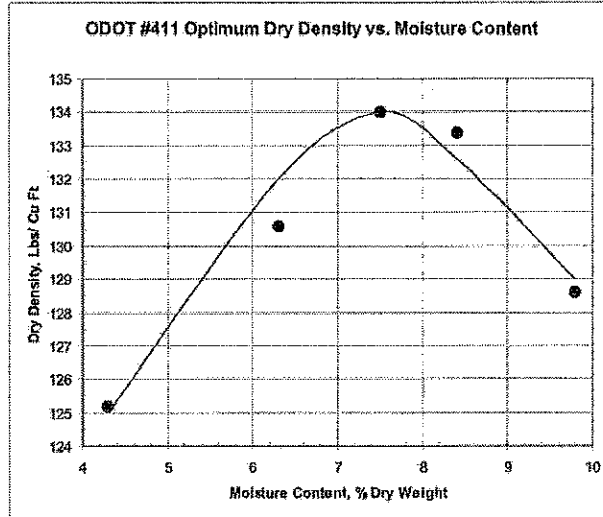

**ODOT #411 Proctor Test Results  
Figure 7.1**

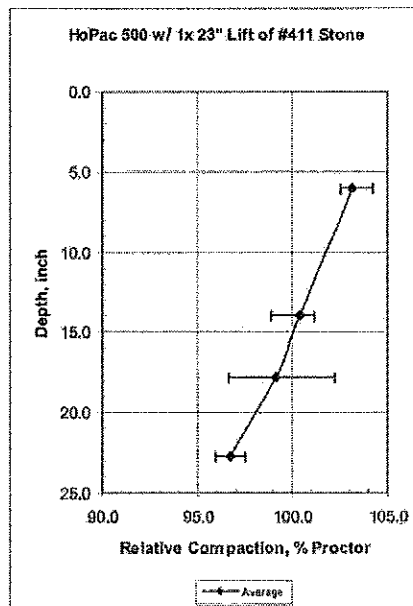

**Compaction Results Ho-Pac 500  
Figure 7.2**

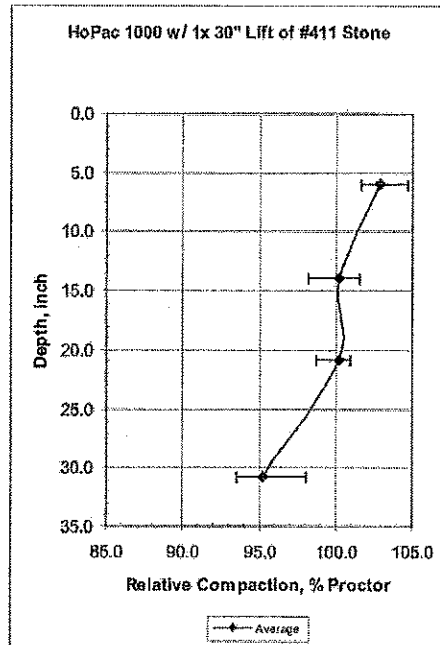

**Compaction Results Ho-Pac 1000  
Figure 7.3**

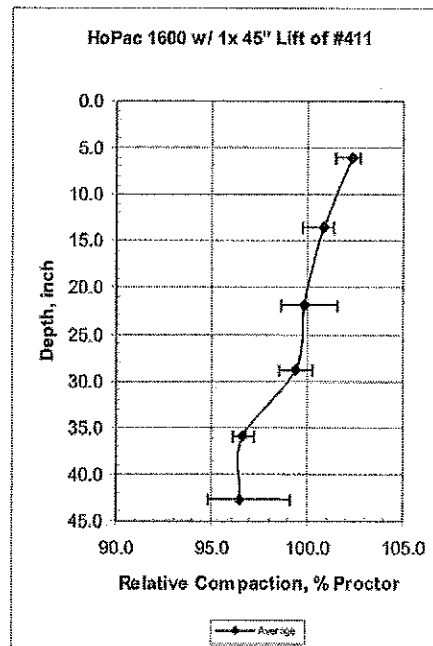

**Comparison Results Ho-Pac 1600  
Figure 7.4**

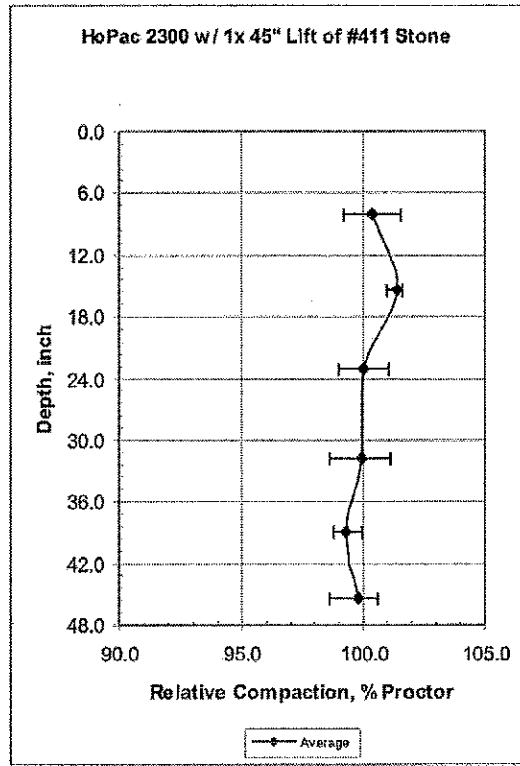

**Compaction Results Ho-Pac 2300**  
**Figure 7.5**

## Section 8.0

### Other Operations with Allied Compacting Equipment

Allied Construction Ho-Pac compactor /drivers may be used for certain other operations in addition to soil compaction.

#### 8.1 Pile driving

The Ho-Pac compactor/driver may be used to drive and extract load bearing pilings, posts and sheet piling. Timber posts, steel sheet piles, "H" or "I" beams can be driven into many different soil conditions including clay, sand, and rocky soils. Successful installations in lengths up to 60 feet are reported. Results are dependent on Ho-Pac model, post/pile material, and soil conditions.

##### 8.1.1 Theory

Direct contact between the vibrating compaction plate and pile transfers motion to the pile. The pile vibration induced by the Ho-Pac is then transferred to the surrounding soil.

Within a specific frequency and intensity range, the vibrating soil particles will tend to easily move past and around one another, or liquefy. This liquefaction also results in reduced friction on objects in contact with the vibrating soil. Therefore, with relatively moderate down pressure, a pile can be inserted into normally compact soil. Since this driving technique relies on soil particle movement, the effectiveness of vibration pile driving is increased with granular soil content and is not well suited for soil with high clay content.

Once the pile is inserted to the desired depth and the vibration is ceased, the irregular soil particles stop moving and interlock with one

another again. Friction increases to normal static conditions between the particles and on the object (pile or post) within the soil. For most piles, the majority of bearing capacity is developed through skin friction with the soil.

Unlike traditional hammer pile driving where 'Blows-per-Foot' is commonly used to determine a pile load carrying capability, there is no direct correlation between the Ho-Pac vibration capability and pile load capacity. To determine load capacity, either static loading or traditional pile driving techniques must be performed to verify the pile's capacity for specific soil conditions.

##### 8.1.2 Technique

When driving posts and piles, the best results are achieved when the Ho-Pac is in contact with the post/pile and down pressure is applied. Position the Ho-Pac with the front 1/4 to 1/3 of the compaction plate in contact with the post/pile. The Ho-Pac is most effective when oriented perpendicular to the post/pile. Limit the down pressure to avoid over stretching the spring mounts or contacting the upper with the compaction plate.

A deep rumbling sound will result when the Ho-Pac is operating effectively. For hard soil conditions, it may be necessary to use the front edge of the compaction plate. This increases the vibration amplitude, but it also makes positioning more difficult. While a small amount of "slapping" is acceptable, excessive "slapping" can result in excessive vibrations, and Ho-Pac, carrier or post/pile damage.

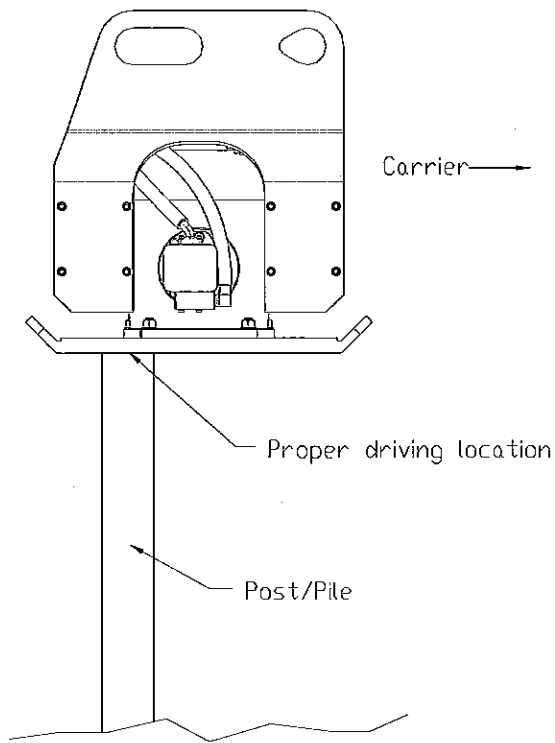

Brackets or guides may be welded on the bottom of the Ho-Pac compaction plate to assist the operator with proper engagement. Also, a Ho-Pac swivel attachment allows more flexibility in carrier positioning.

A Ho-Pac can also be used to extract a post/pile. In this application, a mechanical stop must be added to the Ho-Pac to prevent overstretching the spring mounts as the post/pile is pulled upward.

Special piling and post driver/extractor attachments are available. For more information, contact your Allied Construction Products distributor.

## 8.2 Other applications

Ho-Pac vibratory compactors may also be used for other operations such as waste compaction and break-up of frozen material, i.e., coal and gravel.

## Section 9.0 Definition of Terms/Glossary

**AASHO:** American Association of State Highway Officials

**AASHTO:** American Association of State Highway Transportation Officials

**Amplitude:** Total vertical distance from the neutral position that the vibrating drum or plate is displaced

**ASTM:** American Society for Testing and Materials

**Backfill:** Material used to refill an excavation

**Bank yards:** Measure of soil volume in its original position before digging

**Binder:** Fines that fill voids in soil or hold gravel together when dry

**Centrifugal force:** Unbalanced force generated by an eccentric weight rotating at a given speed

**Clay:** Soil composed of microscopic platelets of rock

**Cohesion:** A property that causes soil particles to stick together and resist compaction

**Compacted yards:** A measure of soils or rock after it is placed and compacted in a fill

**Compressibility:** Property of soil that allows it to deform under load

**Density:** The ratio of the weight of a quantity of soil to its volume, expressed as lb/ft<sup>3</sup>, etc.

**Elasticity:** A property of soil that allows it to compress or deform when a force is applied, but returns it almost to its original configuration when the force is removed

**Expansive Soil:** A soil that swells when wetted and shrinks when dried.

**Fines:** Minute clay or silt particles in soil

**Frequency:** Rotational speed of the eccentric shaft of a vibratory compactor, expressed as vibrations per minute

**Granular material:** Soil with sandy or gritty particles that are coarser than cohesive (clay) soil particles and do not tend to cohere to each other

**Gravel:** Loose, rounded fragments of rock varying from 3.0 inches to .08 inches

**Gumbo:** Soil material in a plastic sticky state, with a soapy or waxy appearance

**Humus:** Organic portion of soil formed by decaying plant or animal matter

**In situ:** Soil or other material in its natural, original place

**Lift:** A layer of soil or other material before or after compaction

**Liquid limit:** The water content at which soil passes from a plastic to a liquid state

**Loam:** A soft, easily worked soil consisting of clay, silt, sand and decayed vegetable material

**Operating weight:** Weight of the compacting device, including all fluids and attachments (same as Working weight)

**Optimum moisture content:** The amount of moisture in a soil required to achieve the greatest dry density of that soil through compaction. Expressed as a percent

**Pass:** A single series of applications of the compacting device across the surface to be compacted

**Permeability:** The ability of water to freely pass through soil

**Plasticity:** The ability of soil (such as clay) to retain its shape when rolled into a fine strand

**Proctor test:** A standardized laboratory test method for determining the maximum density of soil that is used to establish field compaction specifications, commonly expressed as “% Proctor.”

**Proctor test, modified:** A variation of the Proctor laboratory test for high-shear strength soils

**Pumping:** A “spongy” condition in compacted soil where excess moisture prevents soil particles from settling firmly together although the soil may be at or near its maximum density.

**Sand:** A loose granular material composed of mineral particles smaller than gravel, but larger than silt.

**Shearing resistance, strength:** The resistance of soil particles to sliding against one another when compacting force is applied, resulting from interference (friction) and cohesion.

**Silt:** Soil composed of particles between 0.005 and 0.050mm in diameter

**Soil:** Loose material in the upper layer of the earth’s crust composed variously of mineral, vegetable and animal particles

**Working weight:** See Operating weight

## **Section 10.0**

### **References and Further Reading**

American Society of Testing and Materials, D698-00a Standard Test Methods for Laboratory Compaction Characteristics of Soil Using Standard Effort

Website: [www.astm.org](http://www.astm.org)

"Construction and Materials Specification Book", Ohio Department of Transportation (ODOT), Office of Construction Administration

Website: [www.dot.state.oh.us/construction/oca/](http://www.dot.state.oh.us/construction/oca/)

Model 3430 Manual of Operation and Instruction, Troxler Electronic Laboratories, Inc.

Website: [www.troxlerlabs.com](http://www.troxlerlabs.com)

Chapter 8, Soil Compaction, FM 5-410 Military Soils Engineering, U.S. Army Corp of Engineers



## New Ho-Pac Limited Warranty

### WHAT IS COVERED

Allied warrants to owners of new Allied Ho-Pacs that, for a period of twelve (12) months after delivery and placement into service by the first user, the authorized Allied Distributor in whose service area the unit is operated will repair or replace any part that fails because of defects in material or workmanship according to the following schedule:

<u>ITEM</u>	<u>WARRANTY LIMITATIONS</u>		<u>REPAIR CHARGES TO BE PAID BY OWNERS</u>	
	Months	Hours	Parts	Labor
Unit	0 - 12	No Limit	No Charge	No Charge
Main Housing, Eccentric Assembly	7 - 18	No Limit	No Charge	100% of Distributor's Charge

### WHAT IS NOT COVERED

This warranty does not cover:

- conditions which in the reasonable judgement of Allied, arise from misuse, negligence, alteration, accident, or lack of performance of necessary maintenance;
- normal maintenance service or the replacement of service items made in connection with normal use, wear and tear, or maintenance;
- damage due to operation with hydraulic flow, pressure or temperature in excess of levels recommended by Allied;
- claims for loss of time, inconvenience, loss of use of the product or other consequential damages.

### OWNER RESPONSIBILITY

The owner is responsible for:

- the performance of regular maintenance service as specified in the applicable product manuals;
- delivering the product or part to the Allied Distributor.

*This limited warranty is expressly in lieu of any other warranties, express or implied, including any implied warranty of merchantability or fitness for a particular purpose, and any non-contractual liabilities including product liabilities based upon negligence or strict liability. Allied does not authorize any other person to create for it any other liability in connection with this product.*

Allied Construction Products, LLC  
3900 Kelley Avenue  
Cleveland, Ohio 44114 USA





3900 Kelley Avenue, Cleveland, Ohio 44114  
 Tel: 216-431-2600 Fax: 216-431-2601  
 Toll Free: 1-800-321-1046  
 e.mail: CustSvc@AlliedCP.com  
 website: www.AlliedCP.com

# WARRANTY REGISTRATION & DELIVERY INSPECTION REPORT

\*Use this form for hammers and Ho-Pac's®

MODEL No.	SERIAL No.

## PURCHASER AND/OR USER

Name \_\_\_\_\_

Street \_\_\_\_\_

City \_\_\_\_\_ State \_\_\_\_\_ Zip \_\_\_\_\_ Phone ( ) - \_\_\_\_\_

Date delivered to Purchaser / User  
 mm dd yy  
 / /

## SUPPORTING EQUIPMENT

Carrier Mfr. and Model No. \_\_\_\_\_ Hydraulic oil type and grade \_\_\_\_\_

Serial No. \_\_\_\_\_ Hour meter \_\_\_\_\_ Flow regulator for attachment YES  NO

Max. total output of pumps supplying the attachment \_\_\_\_\_ GPM Relief valve for attachment YES  NO

Main relief setting in carrier's hydraulic circuit \_\_\_\_\_ PSI Oil filter in attachment line YES  NO

## PRE-INSTALLATION FLOW AND PRESSURE CHECKS ON SUPPORTING EQUIPMENT

Record oil flow (gpm) and pressure (psi) at the following pre-set conditions. WARNING! Do not exceed the carrier's main relief valve setting.

Pressure	0	1000	1500	1800	2000	2200	2400	2600	2800	Relief valve psi	Operating psi
Flow										Cracking	HP
Return psi										Full	LP

Remarks: \_\_\_\_\_

## DELIVERY CHECK LIST

<input type="checkbox"/> Check for proper lubrication per Operation/Technical Manual	<input type="checkbox"/> Explain maintenance and lubrication requirements
<input type="checkbox"/> Check retention of mounting hardware and fasteners	<input type="checkbox"/> Explain and stress importance of safety precautions
<input type="checkbox"/> Provide (1) CIMA Safety Manual (Hammers only)	<input type="checkbox"/> Instruct the operator of proper operation
<input type="checkbox"/> Operate attachment to assure proper function	<input type="checkbox"/> Review and explain Operator's Manual to customer
<input type="checkbox"/> Provide 1 each Operator's and Parts Manual (Technical Manual)	<input type="checkbox"/> Explain Allied warranty to the customer
<input type="checkbox"/> Provide Allied warranty document	

Installation made by  Allied dealer  Purchaser  Other \_\_\_\_\_

Signature \_\_\_\_\_ Date mm dd yy / /

Remarks: \_\_\_\_\_

If this delivery inspection did not reveal any discrepancies check here

## AUTHORIZED DEALER/SELLER

## PURCHASER AND/OR USER

The indicated Allied product was properly installed, adjusted and tested for proper operation. The importance of following the operating and maintenance instructions found in the Operator's Manual was explained to the purchaser and/or user.

Dealer Name \_\_\_\_\_

Street \_\_\_\_\_

City \_\_\_\_\_ State \_\_\_\_\_ Zip \_\_\_\_\_

Phone ( ) - \_\_\_\_\_

mm dd yy / /

Dealer's Signature \_\_\_\_\_ Date \_\_\_\_\_

I have received (1) Operator's, (1) Parts (Technical Manual supplied with Ho-Pac) and (1) Safety Manual (Hammers only) and the warranty document for the indicated Allied product. Proper and safe operation as well as the maintenance of the product has been adequately explained.

Purchaser's / User's Name (type or print) \_\_\_\_\_

mm dd yy / /

Purchaser's / User's Signature \_\_\_\_\_ Date \_\_\_\_\_







3900 Kelley Avenue, Cleveland, Ohio 44114  
Tel: 216-431-2600 Fax: 216-431-2601  
e-mail: [Sales@AlliedCP.com](mailto:Sales@AlliedCP.com)  
website: <http://www.AlliedCP.com>