

# PARTS: 48 x 74 ROLLER BUCKET

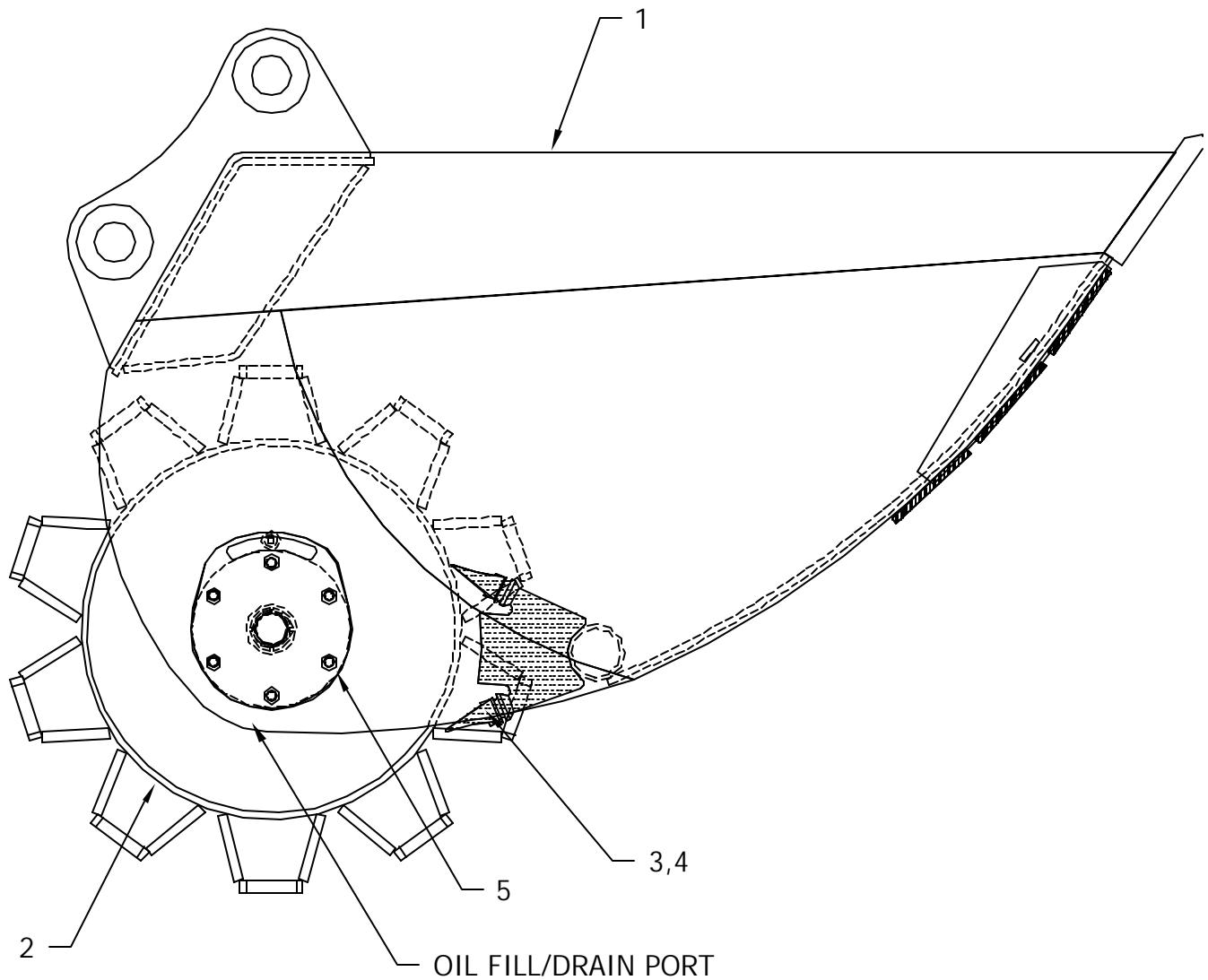

ITEM	PART NUMBER	QTY	DESCRIPTION
1	204663	1	48 X 74 ROLLER BUCKET SHELL
2	203185	1	48" TAMPING WHEEL, COMPLETE
3	920464	14	SCRAPER TOOTH
4	920462	14	LOCK PIN
5		12	$\frac{3}{4}$ x 1 $\frac{3}{4}$ GRD 5 CAP SCREW

# PARTS: 48" 'H' SERIES AXLE ASSEMBLY

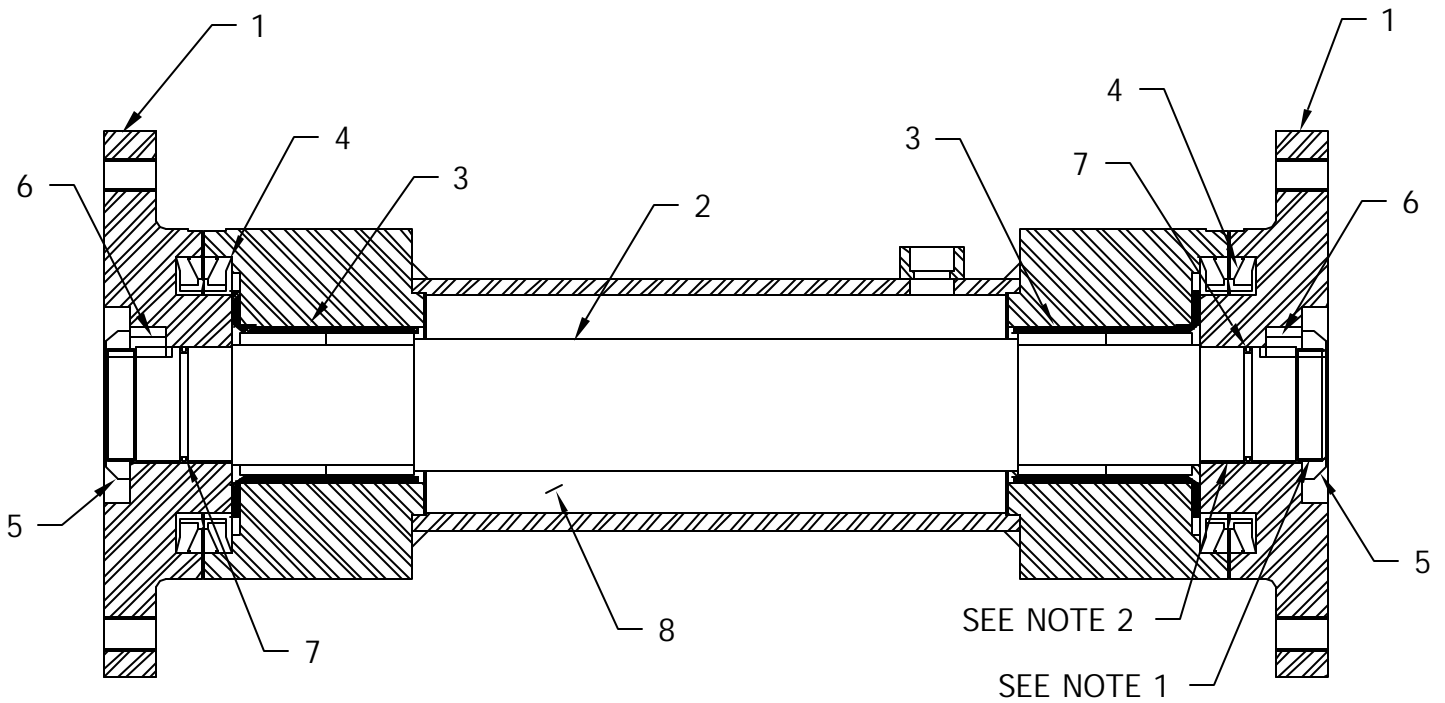

## GENERAL NOTES:

1. USE LOCTITE 262 HIGH STRENGTH, AS PER DIRECTIONS, TYPICAL BOTH ENDS.
2. USE LOCTITE 680, AS PER DIRECTIONS, TYPICAL BOTH ENDS.

ITEM	PART NUMBER	QTY	DESCRIPTION
1	203577	2	CAP
2	203713	1	SHAFT ASSEMBLY
3	920391	2	BEARING
4	920384	2	SEAL
5	920416	2	BEARING LOCK NUT
6	922140	2	½" SQUARE KEY x ¾"
7	920390	2	O-RING
8		3 QTS	30 WEIGHT OIL

# OPTIONAL BUCKET PARTS

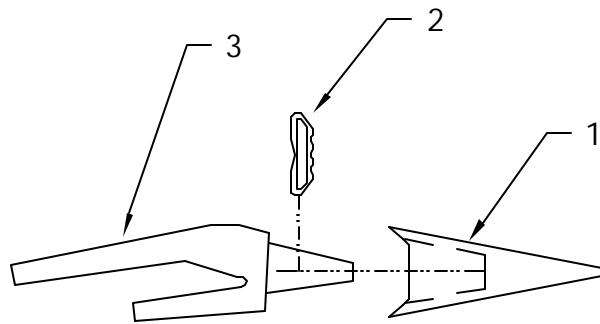

<i>ITEM</i>	<i>PART NUMBER</i>	<i>QTY</i>	<i>DESCRIPTION</i>
<b>1</b>	<b>926370</b>	<b>7</b>	<b>TOOTH</b>
<b>2</b>	<b>920480</b>	<b>7</b>	<b>LOCK PIN</b>
<b>3</b>	<b>920472</b>	<b>7</b>	<b>WELD-ON ADAPTER</b>