

PARTS: 24 x 40 ROLLER BUCKET

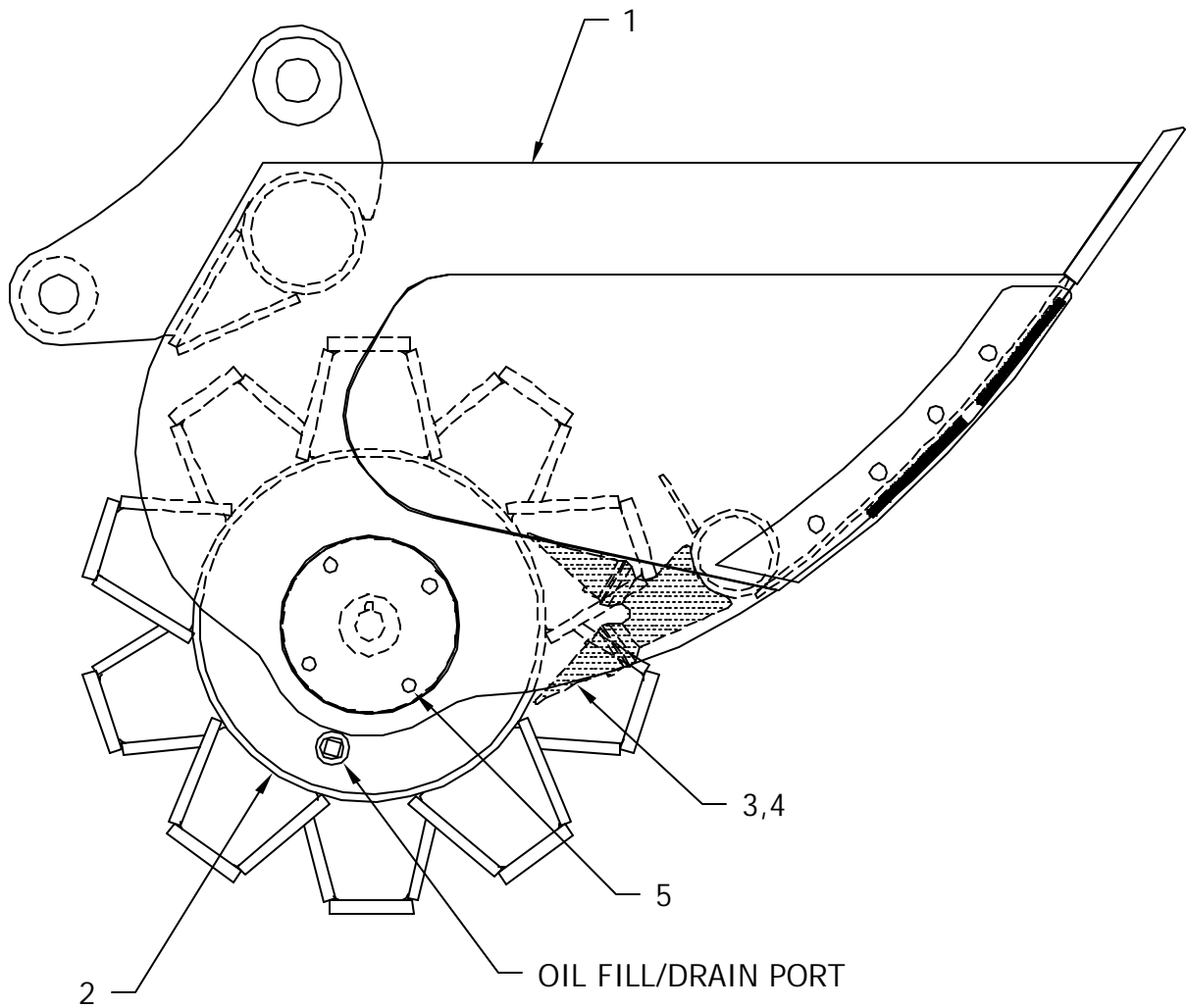

ITEM	PART NUMBER	QTY	DESCRIPTION
1	201617	1	24 X 40 ROLLER BUCKET SHELL
2	201613	1	24" TAMPING WHEEL, COMPLETE
3	920464	6	SCRAPER TOOTH
4	920462	6	LOCK PIN
5		8	$\frac{3}{4}$ X 1 $\frac{3}{4}$ GRD 5 CAP SCREW

PARTS: 24" 'I' SERIES AXLE ASSEMBLY

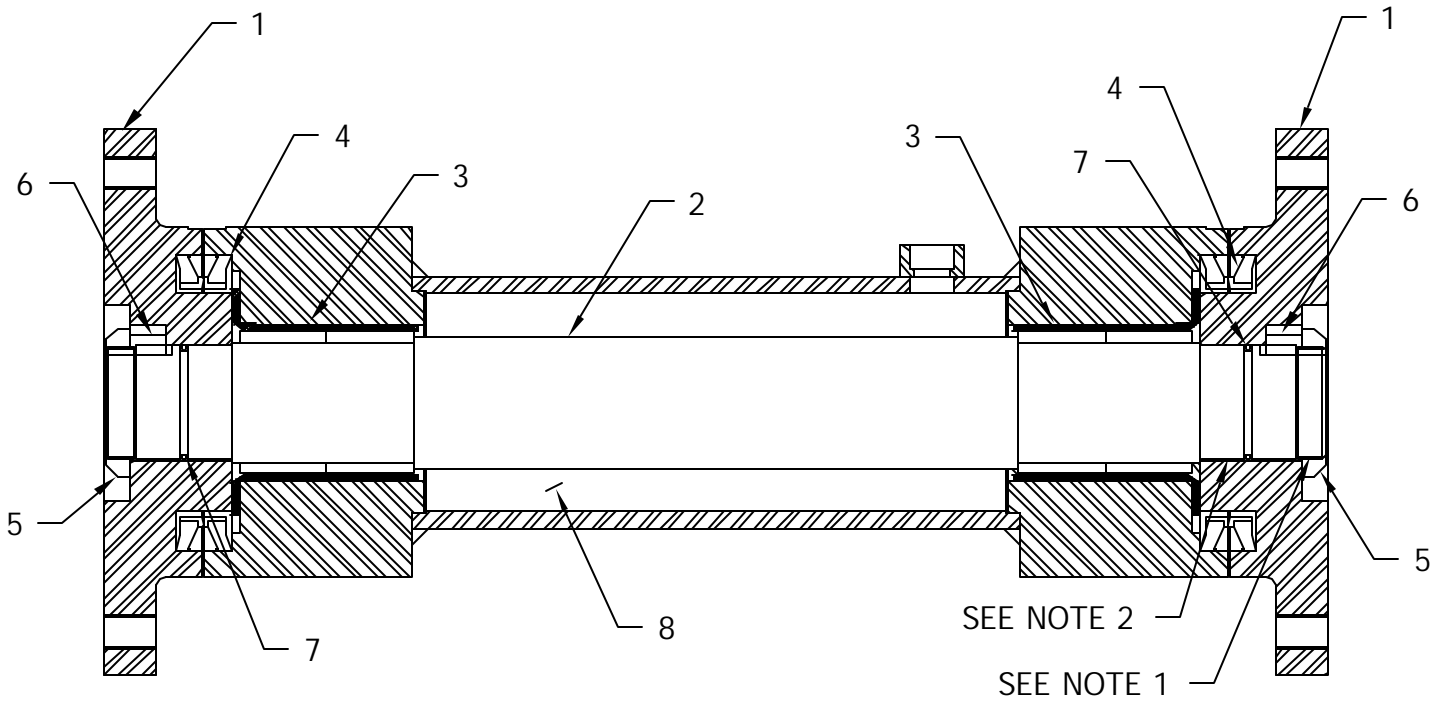

GENERAL NOTES:

1. USE LOCTITE 262 HIGH STRENGTH, AS PER DIRECTIONS, TYPICAL BOTH ENDS.
2. USE LOCTITE 680, AS PER DIRECTIONS, TYPICAL BOTH ENDS.

ITEM	PART NUMBER	QTY	DESCRIPTION
1	203620	2	CAP
2	203626	1	SHAFT ASSEMBLY
3	920387	2	BEARING
4	920401	2	SEAL
5	920429	2	BEARING LOCK NUT
6	922145	2	½" SQUARE KEY x ¾"
7	920397	2	O-RING
8		1 QTS	30 WEIGHT OIL

OPTIONAL BUCKET PARTS

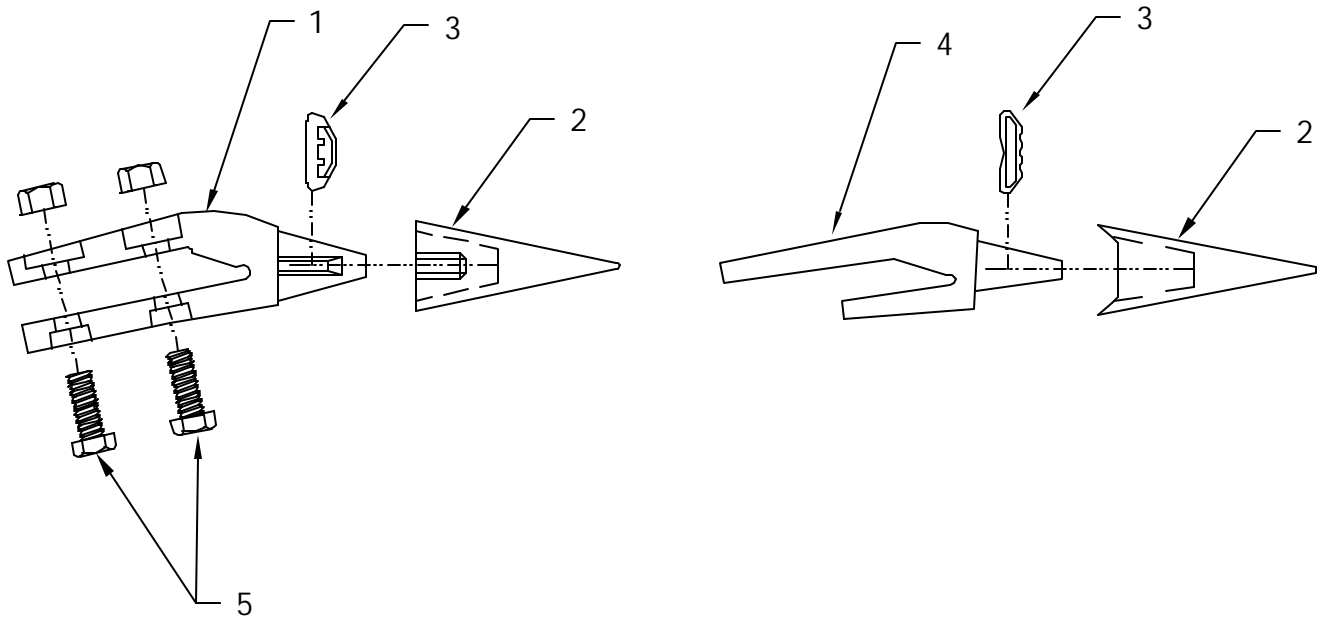

<i>ITEM</i>	<i>PART NUMBER</i>	<i>QTY</i>	<i>DESCRIPTION</i>
1	920465	5	BOLT-ON ADAPTER
2	920464	5	TOOTH
3	920462	5	LOCK PIN
4	920466	5	WELD-ON ADAPTER
5	INCLUDED		MOUNTING HARDWARE